

DVS 2-PHASE FULL DIGITAL STEPPING MOTOR DRIVE

DV556C is a new type of stepper drive developed by DVS company according to the market demand. It adopts the advanced 32-bit DSP chip which is special for motor controlling. DV556C can make a stepper motor run more smoothly and it is not easy to lose steps. Moreover, it can receive input signal pulses, direction signal and enable input signal. When internal position is used, the pulse and direction interface can be used for sensor signal input and accept 485 controlling. DV556C can make the motor create smallest heat and vibration, while the machining speed and precision of the mechanical operation are better improved. The drive voltage ranges from 20V to 50VDC. It is designed for using with 2-phase hybrid stepper motors of all kinds with 42mm to 60mm outside diameter, regulated phase current under 4.0A.

■ Feature

- 2 kinds of motion mode: position mode and speed mode decided by the DIP switch SW4.
- 16 channels micro steps with equal angle and constant torque. Highest micro step: 40000ppr.
- Highest response frequency: 200Kpps.
- The coil current will be reduced by approximately 50% when no step pulse is received for 1.5 seconds.
- Opto-isolated signal I/O.
- Drive current is adjustable in 8 channels from 1.0A/phase to 4.0A/phase.
- Single power supply from 20V to 50VDC.
- Better to overcome the problem of low frequency vibration
- Dimension : 118×24.3×75.5mm³; Net Weight : 0.2Kg

■ Current Setting

Stepper drive working current is set by DIP switches SW1 to SW3. Peak current=working current*1.4.

Working Current (A)	Default	1.2	1.5	2.0	2.5	3.0	3.5	4.0
Peak Current (A)		1.7	2.1	2.8	3.5	4.2	4.9	5.6
SW1	ON	OFF	ON	OFF	ON	OFF	ON	OFF
SW2	ON	ON	OFF	OFF	ON	ON	OFF	OFF
SW3	ON	ON	ON	ON	OFF	OFF	OFF	OFF

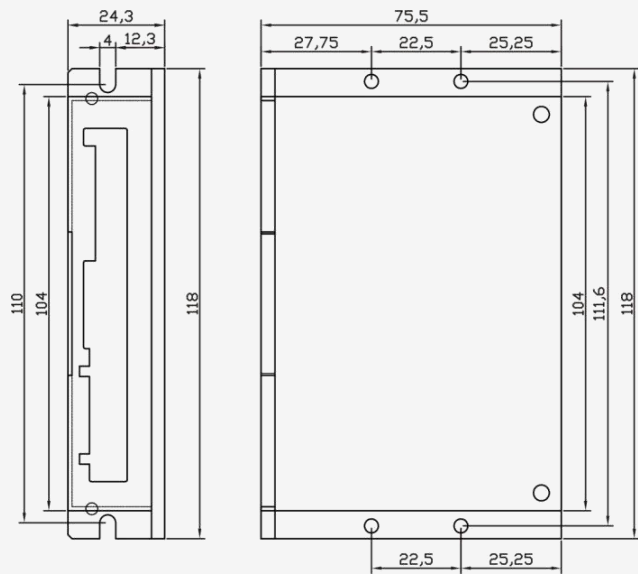

■ Microstep Setting/ I/O Mode Setting

Microstep setting or I/O mode setting is controlled by SW4. If SW4=OFF, it is microstep setting mode. If SW4=ON, it is I/O mode. Microsteps and speed are set by DIP switches SW5 to SW8, 16 channels in total.

Micro step (puls/r)	200	400	800	1600	3200	6400	12800	25600
Speed Value (rpm)	10	20	30	50	60	80	100	150
SW5	ON	OFF	ON	OFF	ON	OFF	ON	OFF
SW6	ON	ON	OFF	OFF	ON	ON	OFF	OFF
SW7	ON	ON	ON	ON	OFF	OFF	OFF	OFF
SW8	ON	ON	ON	ON	ON	ON	ON	ON
Micro step (puls/r)	1000	2000	4000	5000	8000	10000	20000	40000
Speed Value (rpm)	200	250	300	400	500	600	700	800
SW5	ON	OFF	ON	OFF	ON	OFF	ON	OFF
SW6	ON	ON	OFF	OFF	ON	ON	OFF	OFF
SW7	ON	ON	ON	ON	OFF	OFF	OFF	OFF
SW8	OFF	OFF	OFF	OFF	OFF	OFF	OFF	OFF

! Caution

1. The supply voltage shouldn't exceed 50VDC.
2. Input pulse signal is effective with the falling edge.
3. Alarm indicator **ALM** lights and the driver stops working when the drive temperature is over 80°C. It restarts working until the temperature falls to 50°C after repowering on. A heat device is needed when overheat occurs.
4. Alarm indicator **ALM** lights when over current (short of load) occurs. Please check motor's connection and other shorts and turn the power supply on after removing the trouble.
5. Alarm indicator **ALM** lights when no motor is connected or motor connection is poor. Please check motor connection and turn the power supply on after removing the trouble.

■ Terminal Function Introduction

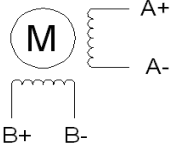
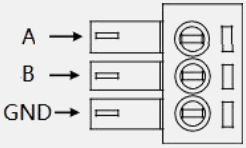
Signal	Function	Remark
PU+	Positive of opto-isolated signal	Connect to +5V signal power supply. For 24V input signal, please switch to connect HSC terminal .
PU-	Step pulse signal	With the falling edge of the signal PU, the motor executes an angular step. The input resistance is 220Ω. Low voltage 0-0.5V, high voltage 4-5V, pulse width>2.5μS.
DR+	Positive of opto-isolated signal	Connect to +5V signal power supply. For 24V input signal, please switch to connect HSC terminal .
DR-	Direction signal	To change the motor rotate direction. Input resistance is 220Ω. Low voltage 0-0.5V, high voltage 4-5V, pulse width>2.5μS.
MF+	Positive of opto-isolated signal	Connect to +5V signal power supply. For 24V input signal, please switch to connect HSC terminal .
MF-	Motor free signal	After turning off the motor working current when it is effective (low level), the drive will stop working and the motor is free.
COM24V HSC	Common 24V terminal	COM 24V is common negative and positive 24V input terminal. When input 24V pulse signal with the common positive connection method, please connect 24V+ signal to COM 24V and 24V- to PU- terminal. For common negative connection method, please connect 24V+ signal to PU+ terminal and 24V- signal to COM 24V terminal.
V-	Negative power supply	DC20V~50V
V+	Positive power supply	
A+	Motor connection	
A-		
B+		
B-		
A	A phase signal for 485 communication	
B	B phase signal for 485 communication	
GND	Ground	

■ Functions Of Input And Output Terminals

In pulse mode, the pulse port and direction port can only receive pulse signal. In I/O mode, the pulse port acts as input port 1 and the direction port as input port 2. Input port 1 defines speed control signal input 1, and input port 2 defines speed control signal input 2, input port 3 defines enable signal input as default.

● **DI Function Introduction**

Value	Signal	Function	Introduction
0	NULL	No function	No function.
1	NEGLIMIT	Negative limit signal	In returning to zero mode, it is used to receive the negative limit signal.
2	POSLIMIT	Forward Limit Signal	In returning to zero mode, it is used to receive the forward limit signal.
3	ORIGIN	Origin signal	In returning to zero mode, it is used to receive the origin signal.
4	SON	Enable signal	For drive enable control: OFF: Drive enabled. ON: Drive diseabled.
5	SPDSIGNAL1	Speed control signal 1	It is used for the input of control signal 1 of the IO port in speed mode.
6	SPDSIGNAL2	Speed control signal 2	It is used for the input of control signal 2 of the IO port in speed mode.
7	STOPSIGNAL	Stop signal	It is used in internal position mode: 1. When returning to zero, to stop returning to zero and complete it. 2. When the position is planned, to stop the displacement and clear the unfinished instruction.
8	POSIO1	Sart signal for Internal position 1	Start the internal position 1 through the I/O port 1 with rising edge,and the internal position 1 is set by the PA51 and PA52.
9	POSIO2	Sart signal for Internal position 2	Start the internal position 1 through the I/O port 2 with rising edge,and the internal position 2 is set by the PA16 and PA17.
10	HOMESTART	Start homing signal	In internal position mode, this port receives the back zero signal with the rising edge.
11	HALTSIGNAL	Suspended signal	1.For internal position mode: when the position planning is carried out, it will suspend the displacement, and at the next coming start signal, it would finish the rest of the trip with the rise edge. 2.For speed mode: after setting themotor speed, as long as the input port is valid, the motor will decelerate and stop working. If it is invalid, the motor will continue to run at the setting speed.
12	POSROUNDIO3	Start signal for Internal second position	Start the internal position 1 and position 2 through the I/O port. The internal position 1 is started with the rising edge , while the internal position 2 is started with the falling edge.
13	SPDSELECT	Speed selection	When in IO speed mode, set PA61 to 2 and it works in the speed of PA41. While the input port level is reversed, it works in the speed of PA42.

■ Drive Wiring Connection Diagram

● 5V Signal Connection

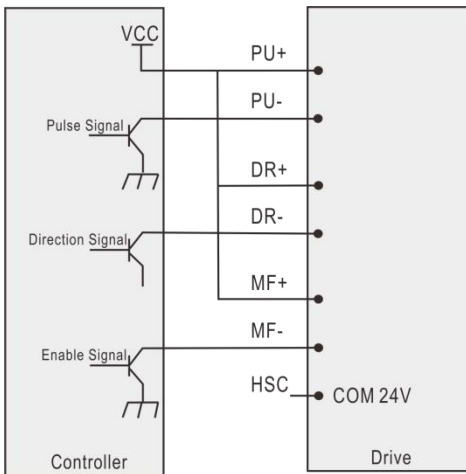

Common Anode Connection

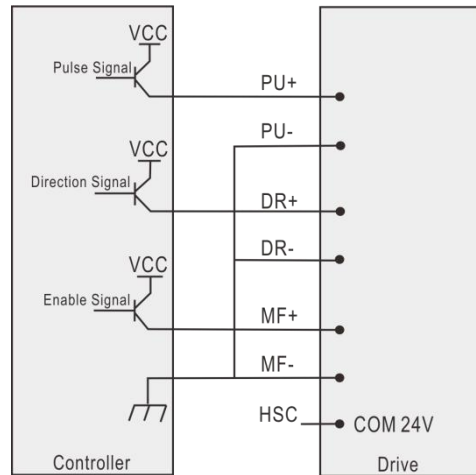

Common Cathode Connection

● 24V Signal Connection

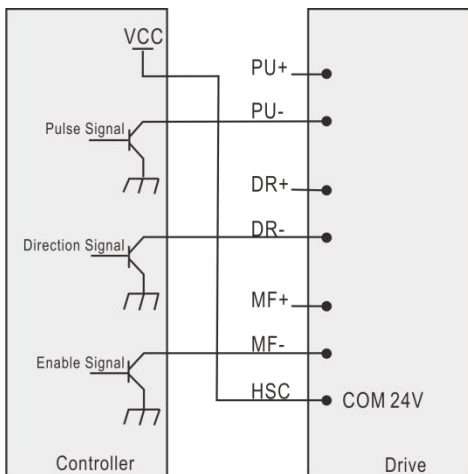

Common Anode Connection

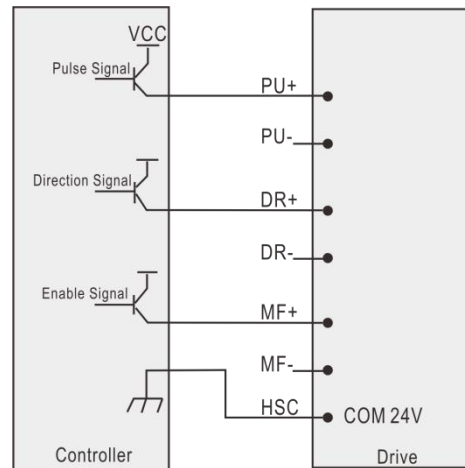

Common Cathode Connection

■ Connection Diagram Between The Drive And PC

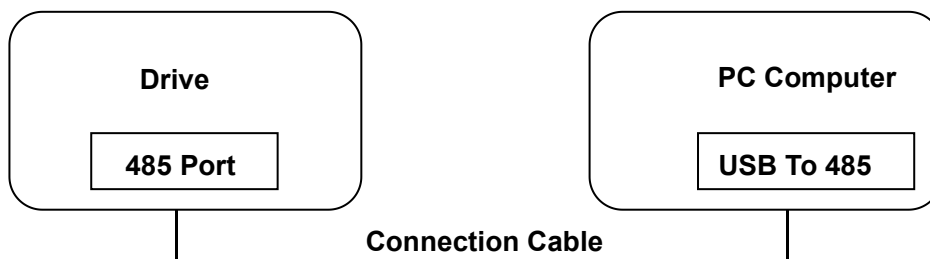

! Note:

- 1、 The cable that the driver is used to connect with a PC machine or STU debugger must be a dedicated cable, please confirm before using to avoid damage.
- 2、 Please use a isolated power supply to the drive when it is connected to a PC machine.

Internal Running Mode

■ ModBus Internal Position And Speed Control Instruction

1. When SW4=OFF , the drive is in pulse mode and it will work by the subdivisions. For example, if the subdivision is set to 1000, the drive will receive 1000 pulses to rotate a revolution.
2. When SW4=ON and PA28=1, it is internal position mode. While PA28=2, it is internal speed mode.

Parameter	Introduction
PA28=2	<p>When PA28=2(as default), it is in internal speed mode.</p> <ol style="list-style-type: none"> 1. PA61=1(as default) is to control starting and stopping through I/O port and the DIP switches to control speeds. The 16 channels of speeds are shown in the silk screen, where the first and second speed can be set by PA41 and PA42. The input port function number is set to corresponding speed control signal 1 and speed control signal 2. The Controlling of the speed of the input signal is set by the PA63. PA63=0(as default): speed control signal 1 for starting and stopping, while speed control signal 2 is CCW and CW functions. PA63=1: speed control signal 1 for forward starting and stopping, while speed control signal 2 reverse starting. 2. PA61=0 is 485 controlling speed mode and the drive works at the speed set by PA53 through 485 controlling. <p>Note: When the driver is in speed mode, the acceleration time and deceleration time from 0 to the target speed can be set according to the PA58 (Rated Speed)and PA54(Acceleration Time), unit:ms. Moreover, acceleration and deceleration are the same and deceleration time and acceleration time are consistent in speed mode. When it is needed to stop the motor rotation, please set the function number of the input port to 11.</p>
PA28=1	<p>When PA28=1, it is in internal position mode.</p> <p>The drive supports two stage positions. PA51 and PA52 set the first stage positio. While PA16 and PA17 set the second segment position. The first stage position can be started by PA50 control word which is discribed in the followings. And the internal position 1 can be set as starting signal by setting the funtion number to 8 of the input port and then it will start this stage position with the rising edge. For the second stage position, it can only start by setting the function number to 9 of the input port with the rising edge.</p> <p>The driver supports returning to zero function and it can work by setting values of PA50. The detailed description as below. Or by setting the input port function number to 10, it can also start returning to zero signal with the rising edge. The mode is set by PA66, and the drive supports mode 17,18,23,27,35 described as below:</p> <p>PA50: Control word 16-bit unsigned number, Bit0-Bit15.</p> <p>Bit 0: With 0->1 rising edge, the drive starts running and follow setting internal position values. The drive will not respond the command until it is finished positioning.</p> <p>Bit 1: With 0->1 rising edge, the internal position stops command and the drive slows down and stops. The rest pulses will be completed in next trip.</p> <p>Bit 2: With 0->1 rising edge, the internal position stops command and the drive slows down and stops. The rest pulses will be cleared. It would follow new setting internal position value in next trip.</p> <p>Bit 3: With 0->1 rising edge, it starts back to zero. Zeroing operation is required before the drive work in internal position mode.</p> <p>Remark: When it is in returning to zero, the internal position can not be started. the internal position run function. A new internal position instruction can not be start until the last internal position has been finished.</p>

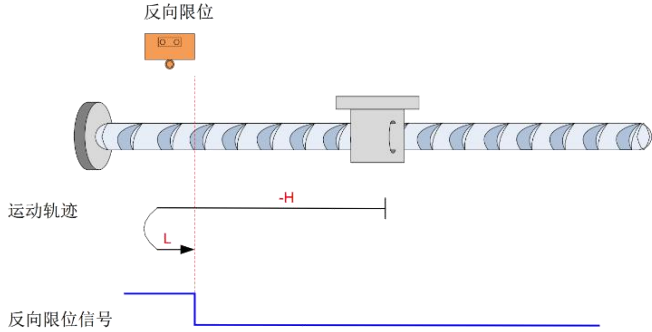
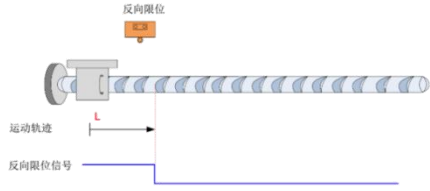
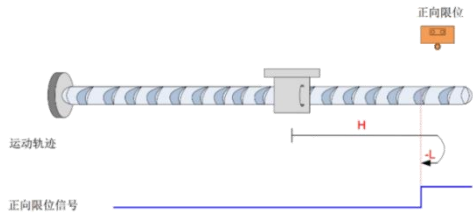
	<p>PA85: The feedback state word in internal position mode which is unsigned 16 bits, and followed by Bit0-Bit15.</p> <p>Bit12 is the internal position flag bit. When it is 1, the driver is planning the position and makes the motor to rotate without responding to a new position start instruction. When the previous displacement has been completed or stopped and it is 0, the drive can respond to a new position start instruction. Bit8 is a bit of finishing returning to zero. When it is 0 and the driver is powered on for the first time, it can start returning to zero and finishes returning to zero after touch the sensor signal and the position is 1. Bit9 is a returning to zero error bit. If there occurs a error in returning to zero, it is 1.</p>
<p>PA66</p>	<p>Returning zero mode selection. And it currently supports mode 17,18,23,27,35. The describe as below:</p>
<p>PA66=17</p>	<p>Mechanical origin: reverse over-range switch. Deceleration point:: reverse over-range switch. A) The deceleration point signal is invalid when homing starts.</p>  <p>Note: In the figure, "H" stands for high speed PA59 and "L" stands for low speed PA60. When homing starts and N-OT =0, it reverses with high speed.. When it encounters N-OT rising edge, it decelerates, reverses and forwards with low speed.. When encountering the falling edge of N-OT, it stops running.</p> <p>B) The deceleration point signal is effective when homing starts.</p>  <p>When homing starts and N-OT=1, it starts to homing at low speed directly, and stops at the falling edge of N-OT.</p>
<p>PA66=18</p>	<p>Origin point: forward over-range switch.. Deceleration point: forward over-range switch. A) The deceleration point signal is invalid when homing starts.</p>  <p>When homing starts and P-OT=0 , it forwards with high speed. When encountering the rising edge of P-OT, it decelerates, reverses and operates at low speed . When encountering the falling edge of P-OT, it stops.</p>

B) The deceleration point signal is effective when homing starts.

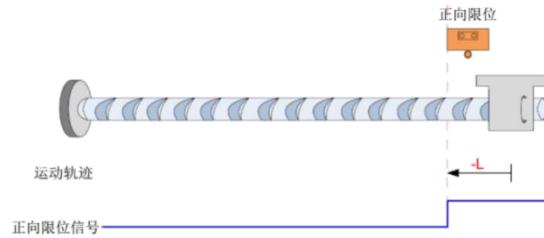

When homing starts and P-OT=1, it reverses with low speed directly. And when encountering the falling edge of P-OT, it shuts down.

Origin point: Origin switch.

Deceleration point: Origin switch.

A) The deceleration point signal is invalid when zeroing starts and it did not encounter the forward limit switch.

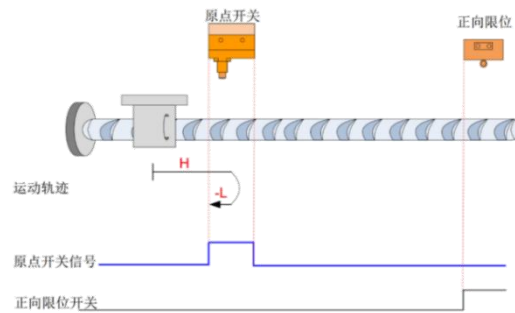

When homing starts and HW=0, it forwards with high speed and does not encounter limit switch. When encountering rising edge of HW, it slows down and reverse with low speed. When encountering the falling edge of HW, it shuts down.

B) The deceleration point signal is invalid when returning to zero starts, and the forward limit switch is encountered.

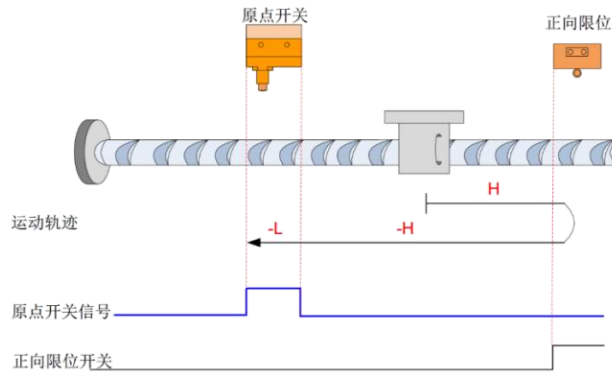

PA66=23

When homing starts and HW=0, it forwards with high speed and encounters limit switch. Then it automatically reverses and runs at high speed. When encountering rising edge of HW, it slows down and keeps reversing with low speed. When encountering the falling edge of HW, it shuts down.

C) The deceleration point signal is effective when returning to zero starts.

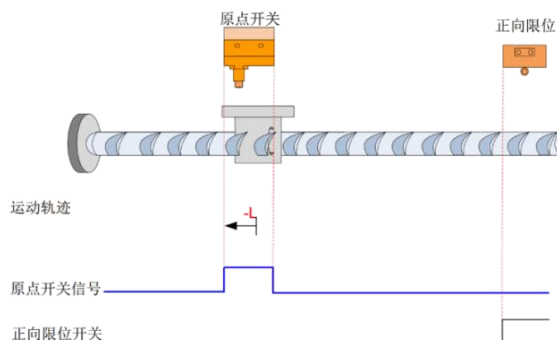

When homing starts and HW=1, it starts zeroing at a reverse low speed directly. When encountering the falling edge of HW, it shuts down.

Origin point: Origin switch.

Deceleration point: Origin switch.

A) The deceleration point signal is invalid when returning to zero starts and did not encounter limit switch.

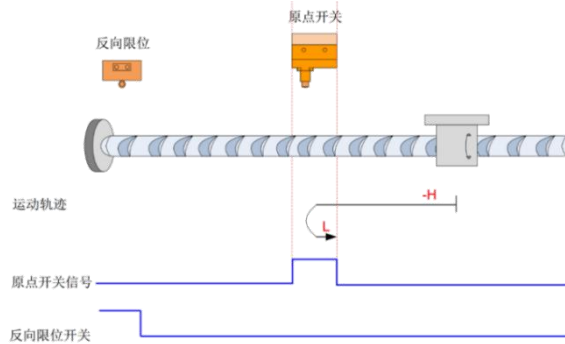

When homing starts and HW=0, it returns to zero with reversed high speed and does not encounter limit switch. When encountering rising edge of HW, it slows down, reverse and forwards with low speed. When encountering the falling edge of HW, it shuts down.

B) The deceleration point signal is invalid when returning to zero starts and the reverse limit switch is encountered.

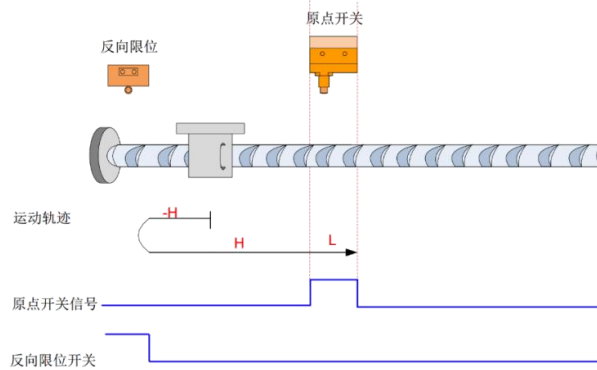

PA66=27

When homing starts and HW=0, it returns to zero with reversed high speed and encounters limit switch. Then it automatically reverses and runs at high speed. When encountering rising edge of HW, it slows down and keeps forwarding with low speed. When encountering the falling edge of HW, it shuts down.

C) The deceleration point signal is valid when zeroing.

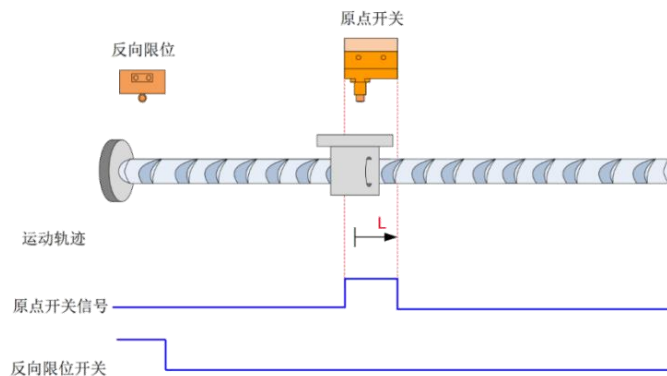

When homing starts and HW=1, it forwards with low speed directly. When encountering the falling edge of HW, it shuts down.

PA66=35

Current position is cleared.

■ I/O Speed Instruction

In external pulse mode, the I/O terminal is as normal pulse and direction functions.



In speed mode : PA61=0, I/O control function is not enabled. When PA61=1, I/O control function is enabled.

When PA28=2, it is speed mode and the motor rotate at the presetting speed , and PA61 makes I/O terminal signal control effective. If PA63=0, PU terminal is starting and stopping signal. Then 5V signal connected starts working, and if 5V disconnected stops working. DR terminal is direction signal. Then if 5V signal is connected, it starts working. And if 5V signal is disconnected , it reverses direction. If PA63=1, PU terminal is CW signal. Then 5V signal connected controls starting working, while 5V disconnected controls stopping. DR terminal is CCW signal. Then if 5V signal is connected, it reverses direction, while 5V signal disconnected stops working. If both of PU and DR connect 5V signal, the motor can only rotate in CW direction.

Parameter Adjustment Software

The drive can communicate with the computer through 485 interface. And a USB to 485 conversion tool is necessary.

Please check the identified serial port number in the computer device manager. Then open the software and select the corresponding serial port. Click “connection the driver” button and there would show that the driver has been connected and the it is online in the lower left corner of the software status bar.

Click the edit parameter button  and open the parameter edit box and then click the read parameter button  to read out parameters in the list.

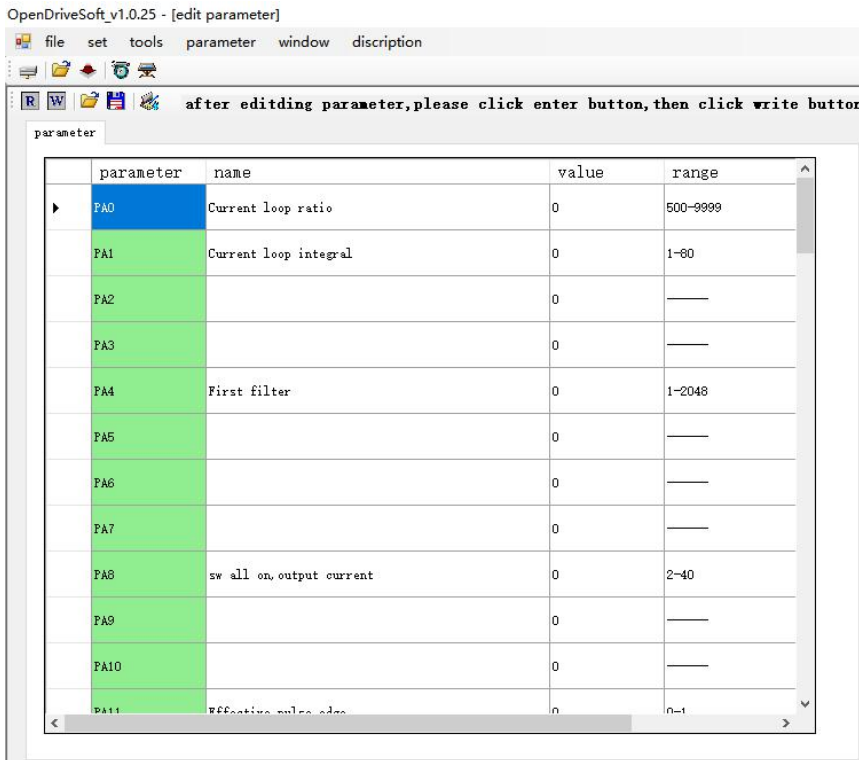

Set SW4=ON to enter into the internal mode and set PA28 to 1 to enter into the internal position mode. Or set PA28 to 2 and PA61 to 0 entering into 485 control speed mode. Please power the drive off and then power it up. Click the point debugging button  on the toolbar. After that, it will enter into 485 control point mode. Be aware that before returning to zero and starting position, please press “control to make clearing” button, and the corresponding function has the control word corresponding bit 0->1 change when starting.

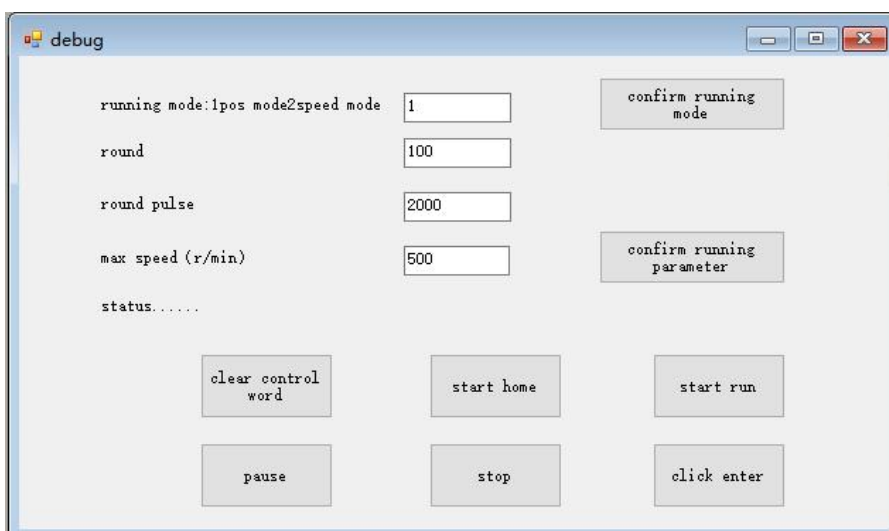

■ Parameter List

No.	Name	Function	Range	Default Value
PA00	Current loop ratio	Current loop ratio.	1000--9000	2000
PA-01	Current loop integral	Current loop integral.	10--100	25
PA-04	The filter coefficient of instruction pulses	The smooth filter of input instruction pulses.	1--2048	128
PA-08	Working current	When all current switches are ON, PA08 can be set as working current,unit: A.	0-1	1
PA-11	Effective pulse edge	0: Rising edge. 1: Falling edge.	0-1	0
PA-12	Electronic gear ratio numerator	It can be used by gear ratio numerator and denominator to achieve any cycle of pulse number. For example: to set the subdivision=1000, if it requires 1314 pulses to rotate a round. Please set the gear ratio numerator as 1000 and the denominator as 1314. Then it can realize that when the controller sends 1314 pulses, the motor rotates a circle.	1--9999	1
PA-13	Electronic gear ratio denominator	The same as above.	1--9999	1
PA-14	Input pulse mode selection	0: Double pulses mode; 1: Pulse+direction mode.	0-1	1
PA-15	Motor rotation direction	0: CW direction. 1: CCW direction.	0-1	0
PA-16	Circle number of internal position 2	To set rotating rounds by internal position IO2.	-9999-9999	-10
PA-17	Number of in-round pulses in internal position 2	For example: if it needs to walk 10.5 rounds, and the subdivision is 4000, please set PA16=10, PA17=2000.	-9999-9999	0
PA-18	Software version	Software version.		
PA-19	Lock current	When the drive stops receiving external pulses, the lock current can set and it is as percentage of operating current. For example, if your operating current is 3A and you set PA19=30%, then the drive current is 0.9A when the drive doesn't work.	1-100	50
PA-20	-	-	-	0
PA-28	Working mode selection	1: Internal position mode. 2: Internal speed mode.	1-2	2
PA-29	ModBus slave address	It is used to set Modbus 485 communication address. If it needs to set communication address through 485, please firstly set slave address to 255 before connecting the drive with the PC in the software as picture showing:	1-255	1

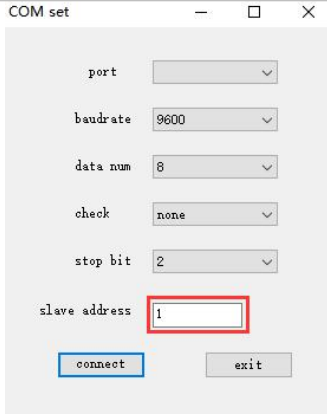
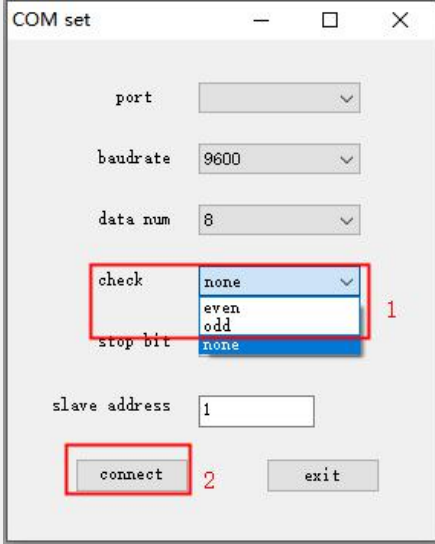
				
PA-30	ModBus baud rate	96 as default and baud rate is 9600. Only 96,144,192,384,560,1152,1280 baud rate settings are supported.	3-1152	96
PA-31	ModBus odd-even check	0: No checking. 1: Odd checking. 2: Even checking.	0-2	0
PA-33	Modbus word length	<p>If PA31 is changed to 1 or 2, PA33 must be changed to 9. And before connecting the drive with PC, please choose odd or even which you set in the software:</p> 	8-9	8
PA-34	Modbus stop bit		1-2	1
PA-35	Restore default parameters	Set this value to 356 to restore default parameters.	0-10000	0
PA-37	Current gain velocity		0-2000	250
PA-38	Current gain coefficient		0-20	7
PA-40	Voltage and current gain	0: The maximum current gain is associated with the voltage. 1: Not associated.	0-1	0
PA-41	Speed 1 controlled by DIP switches	The first speed in the speed mode.	1-1000	10
PA-42	Speed 2 controlled by DIP switches	The second speed in the speed mode.	1-1000	20
PA-43	Function number of input port 1	It is pulse input port as default. When it is set as internal speed and internal	0-99	5

		position, it can be matched with the corresponding function input definition and 5 is speed control signal 1 as default.		
PA-44	Function number of input port 2	It is pulse input port as default. When it is set as internal speed and internal position, it can be matched with the corresponding function input definition and 6 is speed control signal 2 as default.	0-99	6
PA-45	Function number of input port 3	The function is set to the corresponding function input. 4 is the function of enable signal as default.	0-99	4
PA-48	Reverse the effective level of the input port	All are set to 0 for 3 inputs for conduction valid and all are set to 7 for non-conduction.	0-7	0
PA-50	Control word	The parameter is used to control the homing start in internal position mode and for start/stop functions. When it powers off, the function is disabled.	0-8	0
PA-51	Rotating rounds in internal position	To set rotating rounds by internal position IO1.	0-10000	10
PA-52	Number of internal pulses	For example: if it needs to walk 10.5 rounds, and the subdivision is 4000, please set PA51=10, PA52=2000.	0-10000	2000
PA-53	Running speed	1. The fastest speed can be set in internal position mode. 2. The motor speed can be set in 485 controlling speed mode, unit:r/min.	0-1500	500
PA-54	Acceleration time	The required time from speed 0 to rated speed when setting stroke position in internal position mode. The required time from speed 0 to rated speed or from rated speed to speed 0 when in speed control mode or homing mode, unit:ms.	0-10000	5000
PA-55	Deceleration time	The required time to slow down from rated speed to speed 0 when setting stroke position in internal position mode,unit: ms.	0-10000	5000
PA-57	Absolute/relative patterns	0: Absolute position. 1: Relative position.	0-1	1
PA-58	Rated speed	The acceleration can be set coordinating with PA54 and PA55 in position mode. The acceleration and deceleration can be set coordinating with PA54.	0-1500	1000
PA-59	Homing in high speed	Find high speed for the limit switch.	0-1000	60
PA-60	Back to zero in low speed	Find low speed for the origin.	0-1000	10

PA-61	I/O port controls enable in speed mode	0: Internal speed control . 1: Speed controlled by DIP switches.	0-1	1
PA-63	Action selection in speed mode	0: PU and DR terminals for start / stop and CW/CCW function . 1: PU and DR terminals for CW/CCW function.	0-1	0
PA-65	Filtering time of input port	To filter the jitter of input terminals. The value is bigger, the anti-jamming performance is better, but the responded speed is slower.	0-1	0
PA-66	Homing Mode	17: negative limit sensor; 18: positive limit sensor; 23: positive limit and original sensor; 27:negative limit and original sensor; 35: clear current position value and homing can be completed without sensor signal.	0-100	17
Remark: The parameters will be effective after repowering on.				

■ Alarm Code

When it occurs alarming, the driver is offline and the corresponding error code is displayed. Please check the error table to clear the problem. After clearing the failure, the driver can work normally after repowering on.

Alarm Code	Alarm Performance	Introduction
01	Red light always on	Over current alarm
02	Red light flashes 2 times alternately	Over voltage alarm
03	Red light flashes 3 times alternately	Over heating alarm

● Treatment

Alarm Code	Alarm Name	Alarm Reason	Treatment
01	Over current alarm	1. Intelligent module issues. 2. Main Control Chip. 3. Circuit board failure.	1. Check whether the motor wire is wrong. 2. Check whether the motor is damaged. 3. Motor and driver mismatch. 4. Replace drive.
02	Over voltage alarm	1. Circuit board failure 2. Overpowering 3. Power supply voltage waveform is abnormal.	1. Check power supply. 2. Too much motor load. 3. Replace drive.
03	Over heating alarm	1. Circuit board failure. 2. The drive is overheat.	1. Reduce drive heat 2. Replace drive

Note: This version manual is applicable to software version No.29. If there is any modification, please refer to the function supported by the actual software.